

Write your name here

Surname

Other names

**Pearson Edexcel
International GCSE**

Centre Number

--	--	--	--	--

Candidate Number

--	--	--	--

Mathematics B

Paper 1



Monday 11 January 2016 – Morning
Time: 1 hour 30 minutes

Paper Reference
4MB0/01

You must have: Ruler graduated in centimetres and millimetres, protractor, compasses, pen, HB pencil, eraser, calculator. Tracing paper may be used.

Total Marks

Instructions

- Use **black** ink or ball-point pen.
- **Fill in the boxes** at the top of this page with your name, centre number and candidate number.
- Answer **all** questions.
- Answer the questions in the spaces provided
– *there may be more space than you need.*
- **Calculators may be used.**

Information

- The total mark for this paper is 100.
- The marks for **each** question are shown in brackets
– *use this as a guide as to how much time to spend on each question.*

Advice

- Read each question carefully before you start to answer it.
- Check your answers if you have time at the end.
- Without sufficient working, correct answers may be awarded no marks.

Turn over ►

P46912A

©2016 Pearson Education Ltd.

1/1/1



PEARSON

Answer ALL TWENTY NINE questions.

Write your answers in the spaces provided.

You must write down all the stages in your working.

1 Expand and simplify $(5 - 7x)(3 + 2x)$

.....
(Total for Question 1 is 2 marks)

- 2 On Monday 600 cars of different colours were produced in a factory.
Of these cars, 155 were red cars.
A pie chart is to be drawn for the numbers of cars of the different colours produced on Monday.

Calculate the size, in degrees, of the angle of the sector in the pie chart for red cars.

.....
(Total for Question 2 is 2 marks)

3 $y = 3x^2 - \frac{3}{x^3}$

Find $\frac{dy}{dx}$

$\frac{dy}{dx} = \dots\dots\dots$

(Total for Question 3 is 2 marks)



4 Two numbers a and b are in the ratio $a : b = 2 : 5$

Given that $a = 8$, calculate the value of b .

$b = \dots\dots\dots$

(Total for Question 4 is 2 marks)

5 Here are the equations of four straight lines.

$$\begin{array}{ll} y = 1 - x & 3y = 6x + 1 \\ 2y = 5x + 3 & y = 2x + 1 \end{array}$$

(a) Write down the equations of the two lines that have the same gradient.

$\dots\dots\dots$

$\dots\dots\dots$

(1)

(b) Write down the equations of the two lines that pass through the point $(0, 1)$.

$\dots\dots\dots$

$\dots\dots\dots$

(1)

(Total for Question 5 is 2 marks)

Do NOT write in this space



6

North

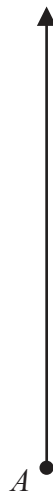

The point A is shown in the diagram.
Points B and C are such that $AB = AC = 5$ cm.
Given that the bearing of B from A is 140°

(a) find and mark the position of B on the diagram with a cross (\times).

Label your cross B .

(1)

Given that the bearing of C from A is 290°

(b) find and mark the position of C on the diagram with a cross (\times).

Label your cross C .

(1)

(Total for Question 6 is 2 marks)



- 7 There is 0.3 kg of tin in a sword.
This is 15% of the total weight of the sword.
Calculate the total weight, in kg, of the sword.

..... kg

(Total for Question 7 is 2 marks)

- 8 Given that $(x - 2)$ is a factor of $3x^3 + x^2 + ax + 4$, where a is a constant,
find the value of a .

$a =$

(Total for Question 8 is 2 marks)



9

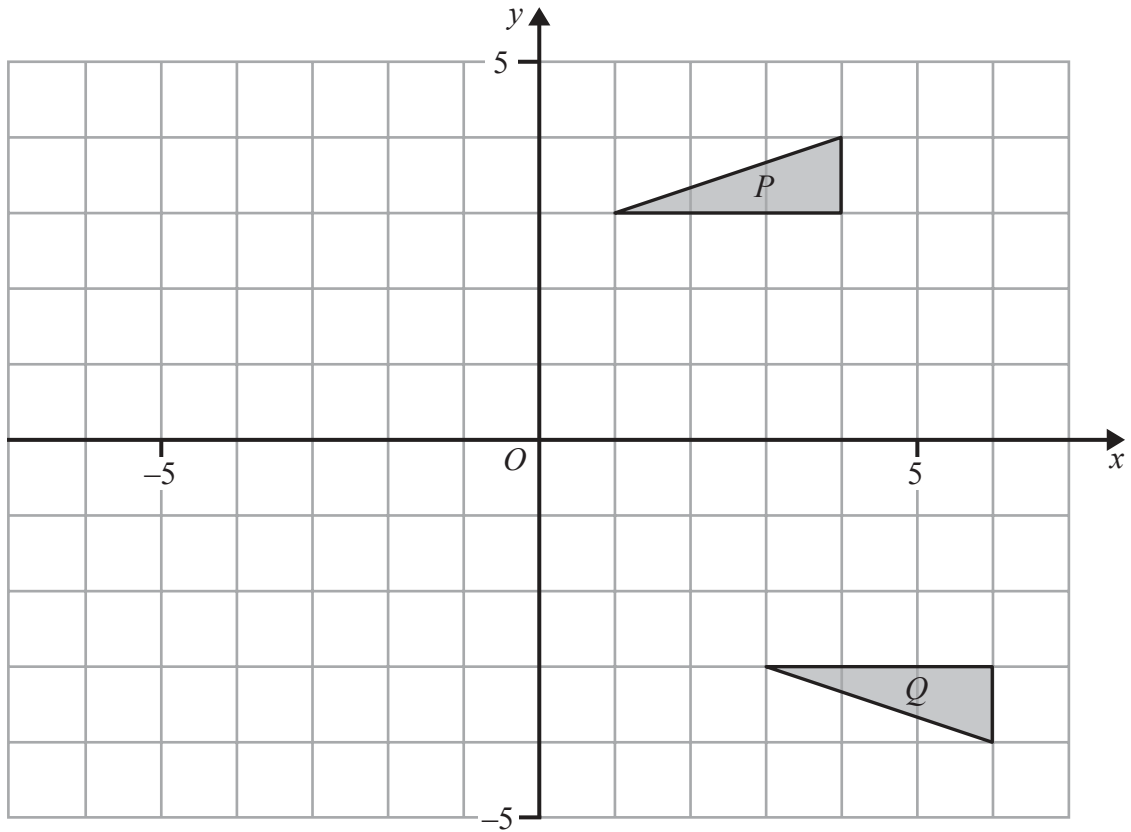

The diagram shows two triangles, P and Q .
 Triangle Q is the image of triangle P under the combined transformation of an anticlockwise rotation of θ° about the origin, O , followed by a reflection in the line with equation $x = a$.

Find the value of θ and the value of a .

$\theta = \dots\dots\dots$

$a = \dots\dots\dots$

(Total for Question 9 is 2 marks)

Do NOT write in this space



10

Diagram NOT
accurately drawn

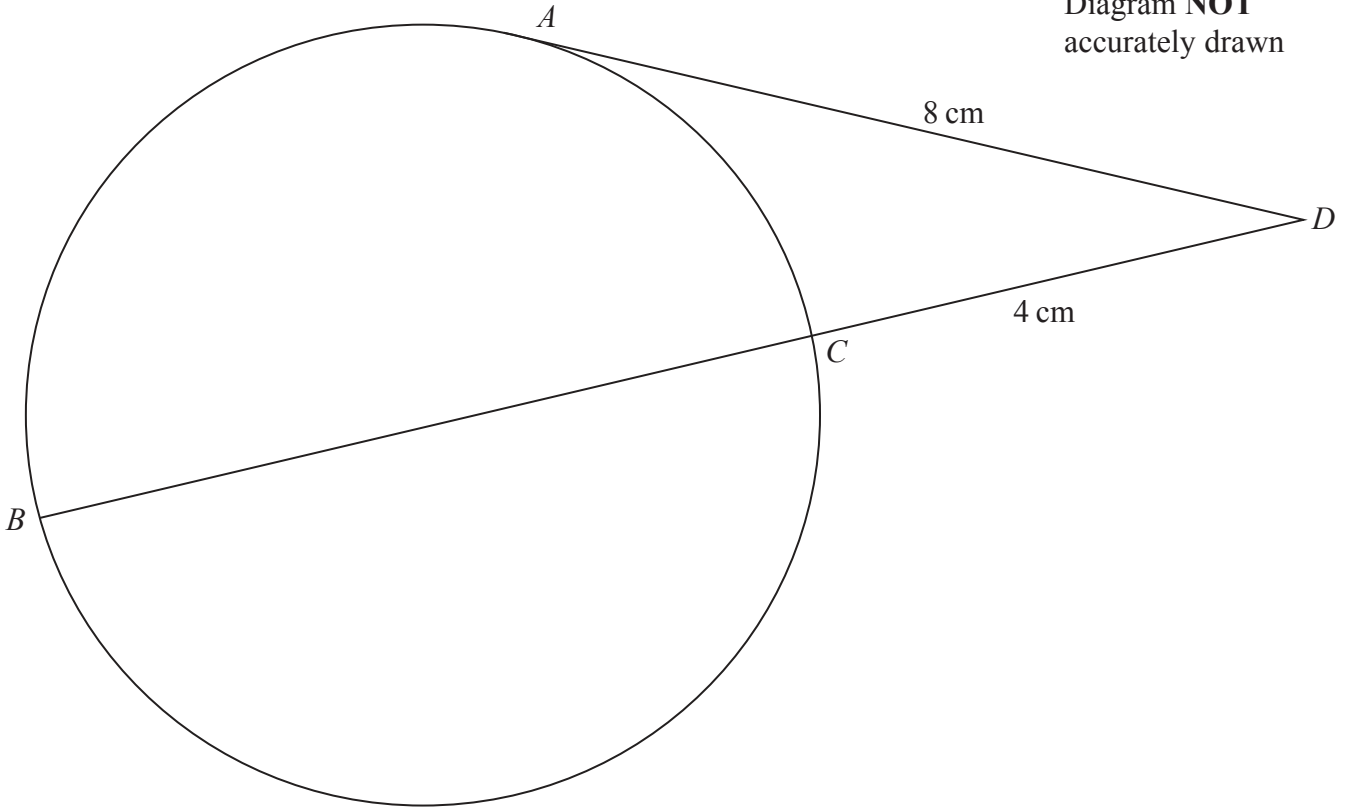

The diagram shows a circle ABC with diameter BC . The point D is such that BCD is a straight line and AD is the tangent to the circle at A .

Given that $AD = 8$ cm and $CD = 4$ cm, calculate the length, in cm, of the radius of the circle ABC .

..... cm

(Total for Question 10 is 3 marks)



- 11 Aktar bought a carpet costing £350.00 (British Pounds) in a shop at an airport. He paid for the carpet with \$200 (US Dollars) and the remainder of the cost of the carpet he paid in British pounds.

The exchange rate was £1 = \$1.54

Calculate how much in British pounds, to the nearest pound, Aktar had to pay after he had paid the \$200

£.....

(Total for Question 11 is 3 marks)

- 12 Find the smallest integer n such that $n - 1 < 8 + 3n$

.....
(Total for Question 12 is 3 marks)



13 Show that $3\frac{1}{3} \div 1\frac{1}{2} = 2\frac{2}{9}$

Show your working clearly.

(Total for Question 13 is 3 marks)

14 $\mathcal{E} = \{0, 1, 2, 3, 4, 5, 6, 7, 8, 9, 10, 11, 12\}$

$A = \{x : 0 < x < 11\}$

$B = \{x : 3 < x < 10\}$

$C = \{x : 0 \leq x \leq 5\}$

List the elements of

(a) A'

.....
(1)

(b) $B \cup C$

.....
(1)

(c) $A \cap B$

.....
(1)

(Total for Question 14 is 3 marks)



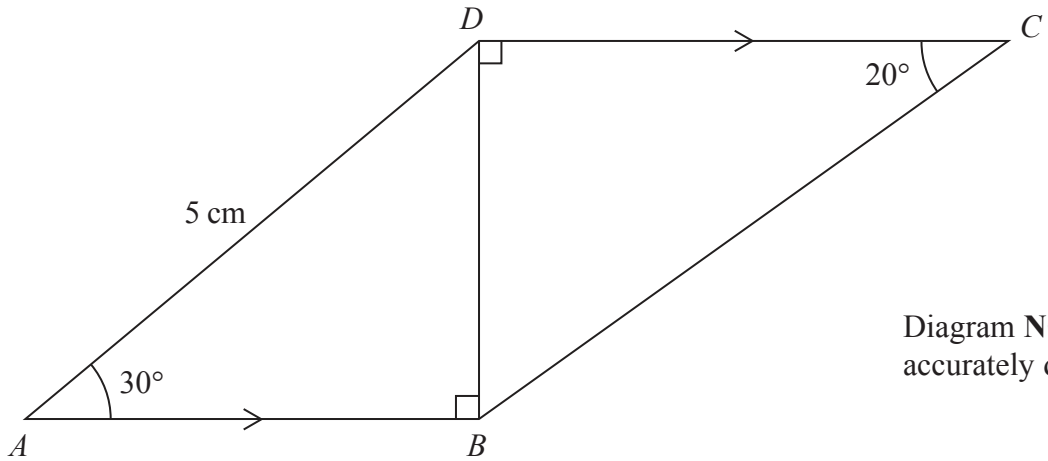

Diagram **NOT** accurately drawn

The diagram shows a quadrilateral $ABCD$ in which AB is parallel to DC and angles ABD and BDC are right angles.

In $ABCD$, $AD = 5$ cm, $\angle DAB = 30^\circ$ and $\angle BCD = 20^\circ$

Calculate the length, in cm to 3 significant figures, of BC .

..... cm

(Total for Question 15 is 3 marks)

16 (a) Write down the order of rotational symmetry of a regular octagon.

.....
(1)

The sum of the interior angles of a regular polygon is 900°

(b) Find the number of sides of this polygon.

.....
(2)

(Total for Question 16 is 3 marks)



17 A curve has the equation $y = 5x^2 - 6x + 15$

Find the x coordinate of the point on the curve at which the gradient of the curve is -2

(Total for Question 17 is 4 marks)

18

$$\mathbf{A} = \begin{pmatrix} 1 & 2 \\ -2 & 1 \end{pmatrix} \quad \mathbf{B} = \begin{pmatrix} -2 & 3 \\ 1 & 5 \end{pmatrix}$$

Find

(a) $2\mathbf{A} - 3\mathbf{B}$

$$\begin{pmatrix} & \\ & \end{pmatrix}$$

(2)

(b) \mathbf{AB}

$$\begin{pmatrix} & \\ & \end{pmatrix}$$

(2)

(Total for Question 18 is 4 marks)



19 Showing all your working,

(a) express $(64x^6)^{\frac{1}{3}}$ in the form $(mx)^m$

.....
(2)

(b) express $(64x^6)^{-\frac{1}{6}}$ in the form $\frac{1}{nx}$

.....
(2)

(Total for Question 19 is 4 marks)

20 Find the two values of x that satisfy the matrix equation

$$(3 \ 7) \begin{pmatrix} x^2 \\ -1 \end{pmatrix} = (4x)$$

$x = \dots\dots\dots$, $x = \dots\dots\dots$

(Total for Question 20 is 4 marks)



21 The length of the perimeter of the square base of a pyramid is 920 m.
The height of the pyramid is 129 m.

Calculate the volume, in m^3 , of the pyramid.
Give your answer in standard form to 3 significant figures.

..... m^3

(Total for Question 21 is 4 marks)

22 A is the point with coordinates $(-2, 9)$ and B is the point with coordinates $(8, -1)$.

Given that M is the midpoint of AB ,

(a) find the coordinates of M ,

(.....,)
(2)

(b) calculate the modulus of the vector \vec{OM} , where O is the origin.

.....
(2)

(Total for Question 22 is 4 marks)



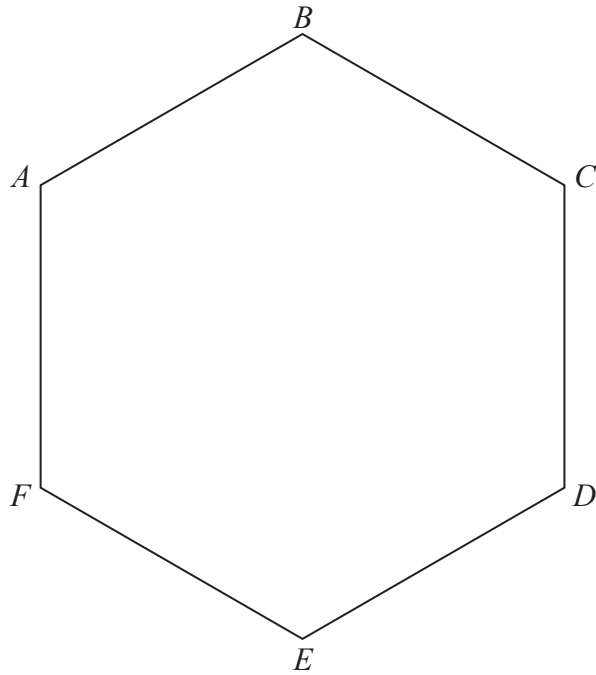

The diagram shows the regular hexagon $ABCDEF$.

Draw the locus of all points inside $ABCDEF$ that are

(a) equidistant from the points B and E , (2)

(b) 6 cm from the point A . (1)

The point P , inside the regular hexagon, is equidistant from B and E and is 6 cm from the point A .

(c) Label the point P and find by measurement the length, to the nearest mm, of the line PD .

$PD = \dots\dots\dots$ mm
(2)

(Total for Question 23 is 5 marks)



24 The y coordinate of any point on the curve C varies directly as the cube of the x coordinate of that point.

The point $A(2, 216)$ lies on C .

(a) Find an equation for C .

.....
(3)

The y coordinate of the point B on the curve C is -343

(b) Calculate the x coordinate of the point B .

.....
(2)

(Total for Question 24 is 5 marks)



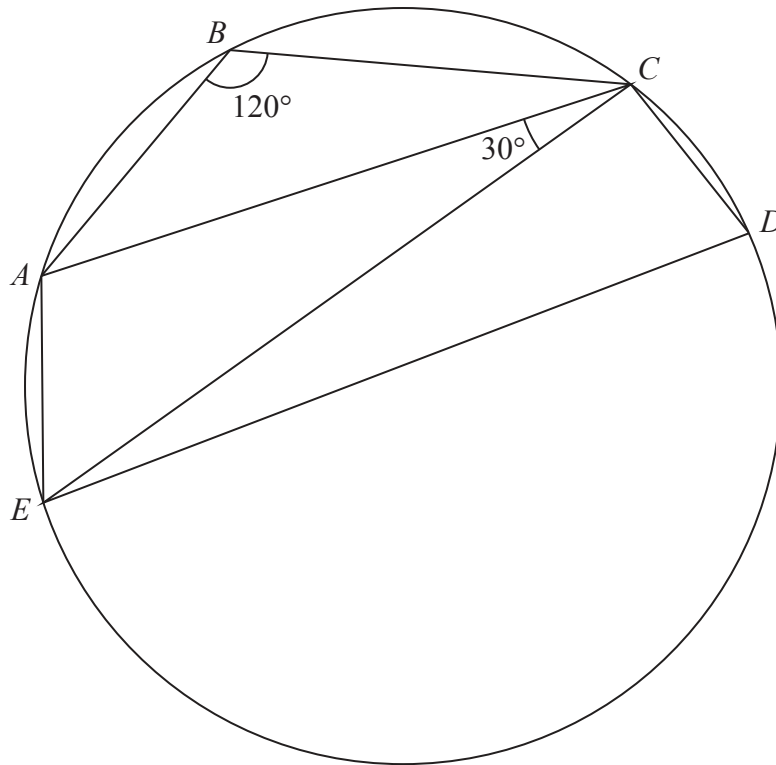

Diagram **NOT** accurately drawn

The diagram shows a circle $ABCDE$ in which $\angle ABC = 120^\circ$ and $\angle ACE = 30^\circ$

(a) Show, giving your reasons, that $\angle EAC = \angle CDE$.

(4)

(b) Explain why EC is a diameter of the circle $ABCDE$.

(1)

(Total for Question 25 is 5 marks)



26

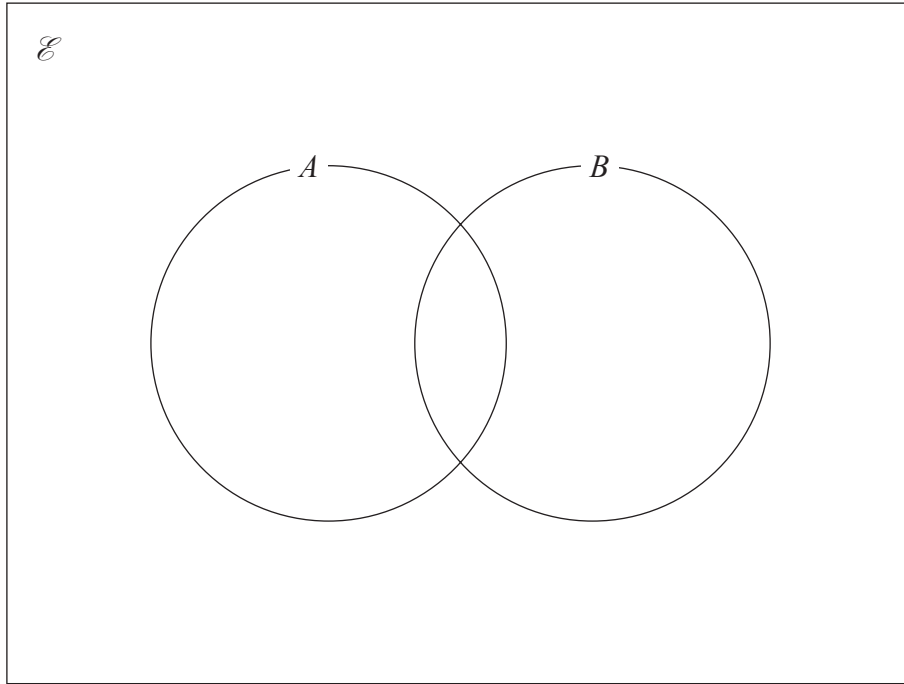

Given that $n(\mathcal{E}) = 40$
 $n(B') = 22$
 $n(A' \cap B) = 8$
 $n(A \cap B') = 6$

find

(a) $n(B)$

.....
(1)

(b) $n(A \cap B)$

.....
(2)

(c) $n([A \cup B]')$

.....
(2)

(Total for Question 26 is 5 marks)



27 The table below gives information about the results of a survey of the ages, t years, of 410 members of a sports club.

Age (t years)	$20 < t \leq 25$	$25 < t \leq 45$	$45 < t \leq 60$	$60 < t \leq 80$
Frequency	80	160	90	80

The diagram below is an incomplete histogram representing this information.

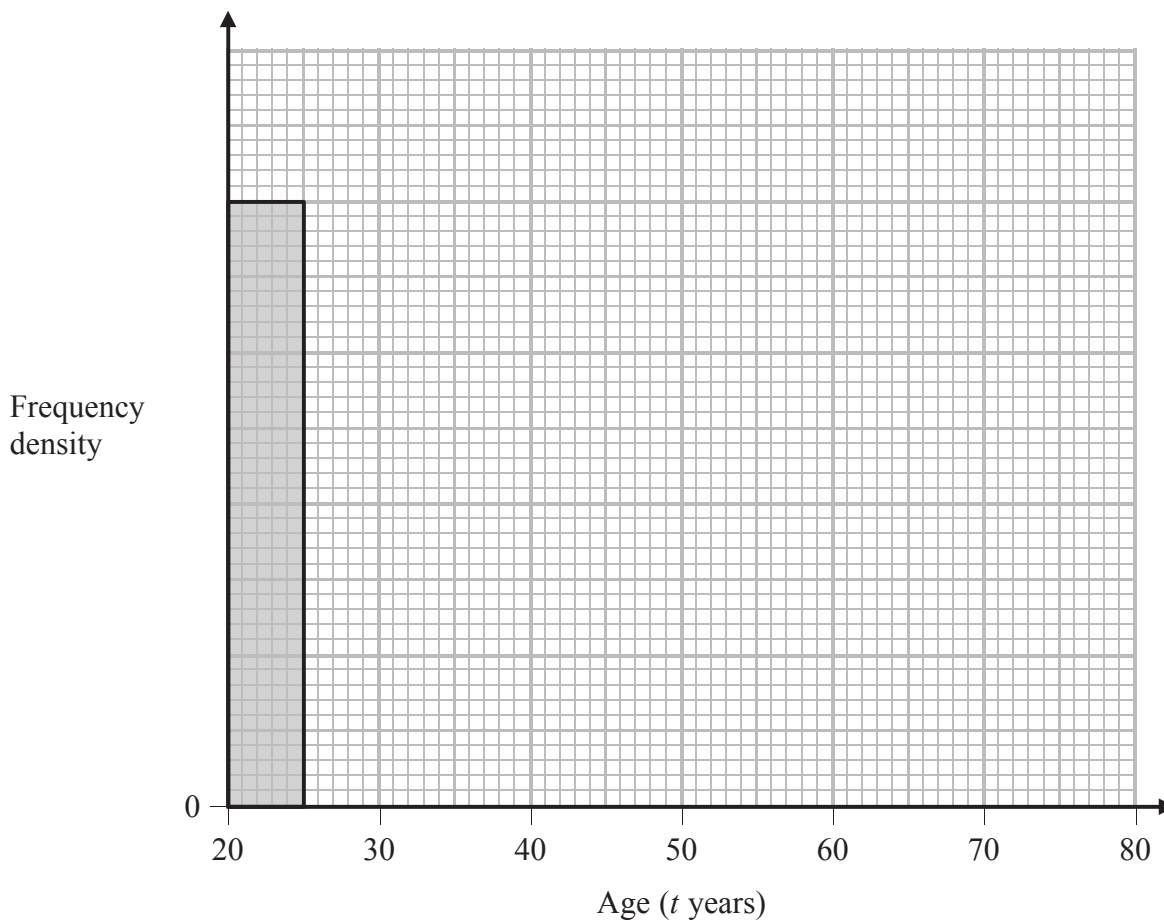

(a) Use the information in the table to complete the histogram.

(2)



(b) Calculate an estimate for the mean age, to the nearest year, of the members of the sports club.

..... years

(4)

(Total for Question 27 is 6 marks)

Do NOT write in this space



28 A train, starting from rest, accelerates at a constant rate and attains a speed of 30 m/s after 30 seconds.

The train then travels at this speed for 5 minutes.

The train then slows down at a constant rate and comes to rest in 1 minute.

(a) Represent this information on a speed-time graph.

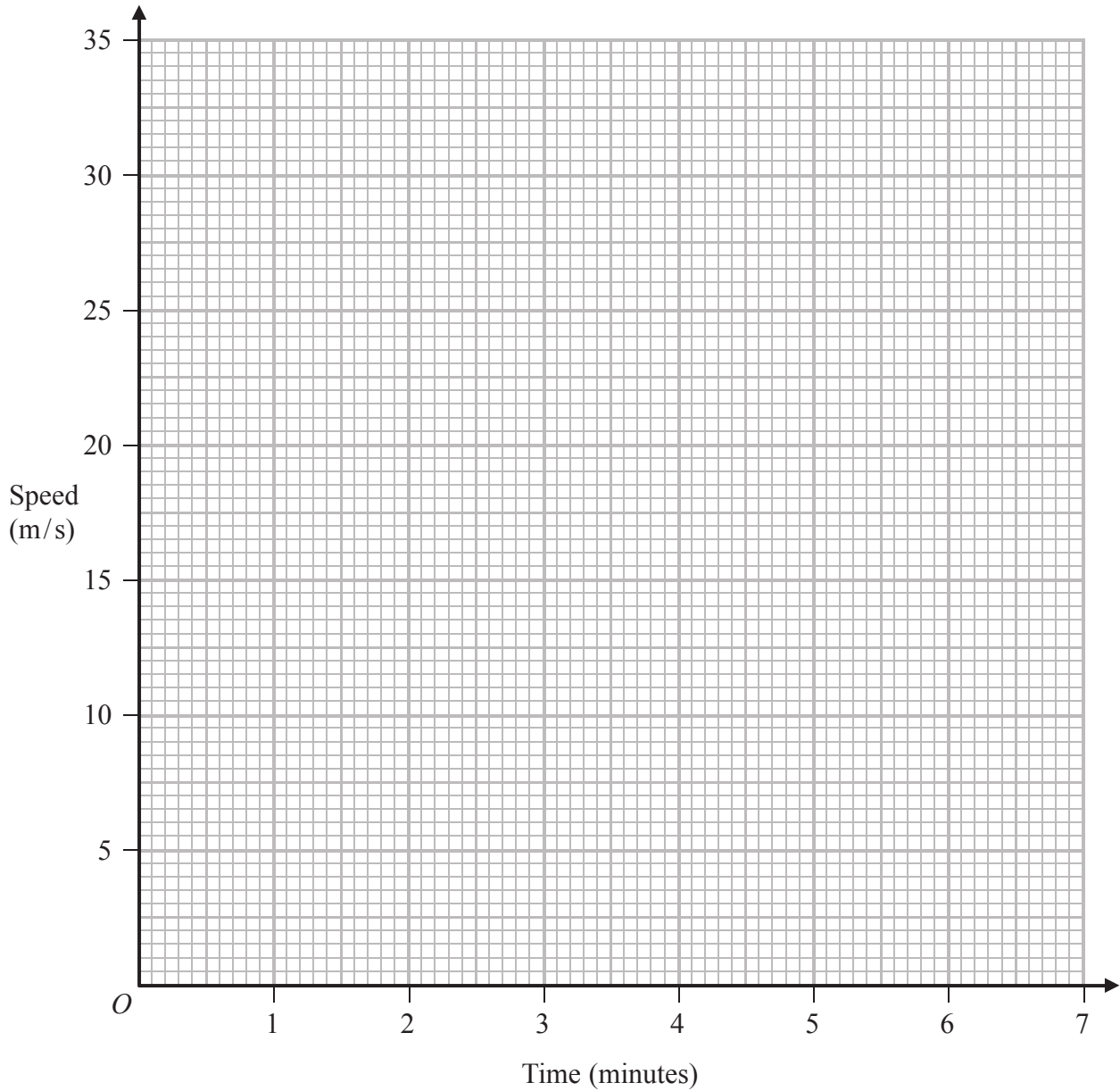

(2)



(b) Find the total distance, in metres, travelled by the train.

..... m
(2)

Find

(c) the average speed, in m/s, of the train,

..... m/s
(1)

(d) the rate, in m/s^2 , at which the train slows down.

..... m/s^2
(1)

(Total for Question 28 is 6 marks)

Do NOT write in this space



29 A biased die has four sides.

The sides are numbered 2, 4, 6 and 8

When the die is thrown, the score is the number on the bottom side.

The table shows information about the probabilities when the die is rolled once.

Score	2	4	6	8
Probability	x	x	$3x$	$2x$

(a) Calculate the value of x .

$$x = \dots\dots\dots (2)$$

The die is thrown twice.

(b) Calculate the probability that the total of the two scores is 12

$$\dots\dots\dots (3)$$

(Total for Question 29 is 5 marks)

TOTAL FOR PAPER IS 100 MARKS



BLANK PAGE

Do NOT write on this page



BLANK PAGE

Do NOT write on this page

